

Carburetor Choke Vacuum Break Control

Mounted on the RH side of 66-75 carburetors, they are linked to the coiled choke springs on the intake. They resembling 2 inverted pie pans, about 1" in dia. After 20-30 years, they are often damaged or rusted out, and can no longer control carb idle & fast idle speed. They are plated Yellow Di-Chromate for most, except as noted.

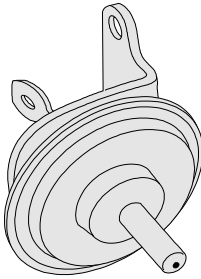

66-70 Holley Choke Controls

66-67 300, 350, 390 HP exc A.I.R.;
67-69 400, 435 HP center carb only
70 370 HP LT-1 exc Calif.
NOS Choke Vacuum Break

3275528 Disc

68-75 Q-Jet Choke Controls

68 Q-Jet Control Nylon 3275530 Disc
69 Q-Jet Control Nylon 3275532 Disc
70-71 Q-Jet Control Nylon 3275534 Disc
72 Q-Jet Control 3275536 0.00
73 L-48 & 454 Control 3275538 45.00
73 L-82 Control 3275540 Disc
74 L-48 Control 3275542 40.00
74 L-82 Control 3275544 45.00
74 454 Control 3275546 45.00

75 Models use 2 Vacuum controls -- a Front Primary control & a Rear Secondary vacuum control.

75 L-48 Primary Control or 76 L-48 or 77 All Control 3275548 45.00
75 L-82 Primary Control or 76 L-82 Control 3275550 45.00
75 Secondary Control 3275552 0.00

Carb & F.L. Mounting Kits

Include combination fine & coarse thread studs, fine thread nuts, & bolts required to mount the carburetor or F.I. to the intake manifold.

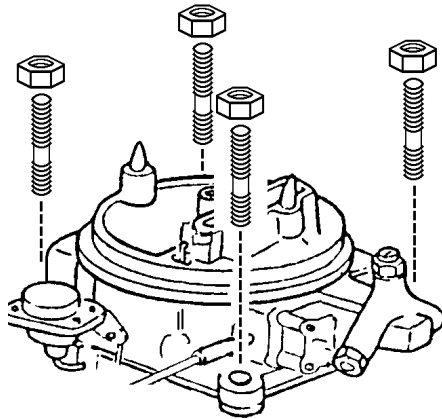

55-62 1x4 8 Piece Kit 3278203 5.00
56-61 2x4 16 Piece Kit 3278205 10.00
57-62 F.I. 16 Piece Kit 3278207 10.00
62 300 HP 8 Piece Kit 3278211 5.00
63-65 250, 340 HP 8 Piece Kit 3278214 5.00
63-65 300 HP 8 Piece Kit 3278216 5.00
63-65 F.I. 16 Piece Kit 3278218 10.00
66-67 1x4 8 Piece Kit 3278220 5.00
67-69 3x12 22 Piece Kit 3278222 12.60
68-70 1x4 Q-Jet 6 Piece Kit 3278224 6.75
71 Q-Jet 6 Piece Kit 3278226 8.00
70-72 Holley 8 Piece Kit 3278228 5.00
72-81 Q-Jet 8 Piece Kit 3278230 8.00

TCS = Trans Control Spark

TCS Switches screw into the LH side of the Transmission

70-74 TCS Switch Mounting Gasket 3275626 5.50
70-71 except Auto TCS Switch 3275628 0.00
72-74 except Auto TCS Switch 3275630 24.00
70-71 with Auto TCS Switch 3275632 20.50
72-73 with Auto TCS Switch 3275634 26.25
70-73 Auto Switch Connector 3275636 15.00
70-73 Auto Switching Lead in Trans 3275638 10.00
70-74 TCS Wiring Harness & Connector 2515291 19.50
70-74 TCS Replacement Connector only 1148100 5.00
70-74 Harness Mounting Clip to Trans 8848986 6.00
70 All TCS Relay on LH Firewall 3275640 Disc
70-73 TCS Sender in Cyl Head **Replmnt** 1148104 20.75
70-73 TCS Sender in Cyl Head **Delco** 1148102 24.50

59-65 WCFB / AFB Inlet Filter

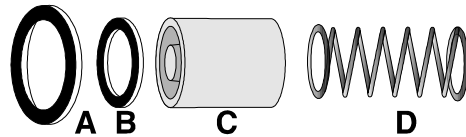

A Inlet Fitting Metal Gasket 3890130 4.50
B Filter Mounting Gasket 3890132 10.00
C Bronze **Delco** Inlet Filter 3890114 4.95
D Filter Mounting Spring 3890134 7.50

64-65 350-365 HP Fuel Inlet Filter

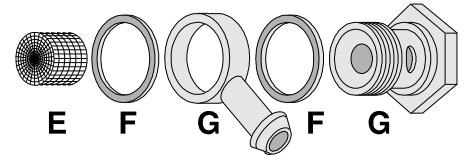

E Inlet Filter Screen Basket 3890136 10.00
F Inlet Fitting Metal Gasket 2 reqd 3890137 2.95
G Inlet Swivel Fitting & Nut 3890138 25.00

65-72 Holley Fuel Inlet Filter

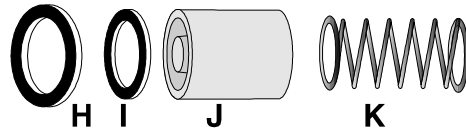

Single feed Holley's require one of each piece;
Dual feed Holley's i.e. 65 396; 66 425 HP; 67-69 L88;
70-72 LT-1 and 71 LS-6 require two of each piece;
Tripower models require three of each piece.
H Inlet Fitting Metal Gasket 3890130 4.50
I Filter Mounting Gasket 3890132 10.00
J Bronze **Delco** Inlet Filter 3890114 4.95
K Filter Mounting Spring 3890134 7.50

68-75 Q-Jet Fuel Inlet Filter

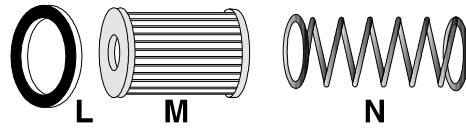

L 68-71 Inlet Fitting Metal Gasket 3890130 4.50
L 72-75 Inlet Fitting Gasket 3890142 4.50
M Pleated Paper **Delco** Fuel Filter 3890116 3.65
N 68-75 Filter Mounting Spring 3890140 10.00

76-81 Q-Jet Fuel Inlet Filter

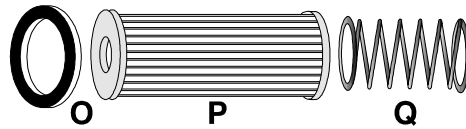

O Inlet Fitting Gasket 3890142 4.50
P Pleated Paper **Delco** Filter 3890118 4.75
Q Filter Mounting Spring 3890144 9.50

NEW RH Side TCS Spark Control Solenoids

Why spend twice as much for a Used ? Rebuilt ? Solenoid. These are BRAND NEW made from the GM tooling.

Model	OE Part #			
70 350 All Trans	1114432	3275604	69.50	
70 454 All Trans	1114434	3275606	0.00	
72 350 All Trans	1114451	3275608	69.50	
72 454 All Trans	1114453	3275610	69.50	
73-74 454 Std Trans	1997411	3275612	69.50	
73-74 350 Std Trans	1997410	3275616	69.50	
73-74 350 Auto Trans	1997425	3275618	69.50	
73-74 454 Auto Trans	1997413	3275620	0.00	
70-74 Solenoid Mount Stud		3890211	6.50	

NEW LH Side Idle Control Solenoids

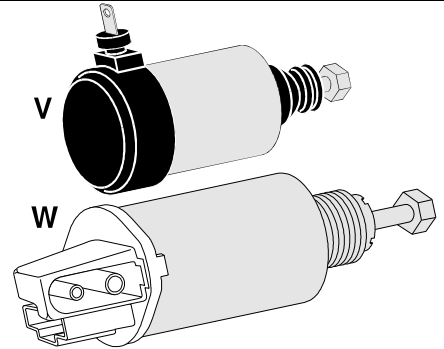

V 68-70 Idle Solenoid **Replacement** 3275600 77.00
68 AC Idle Solenoid **Harness** 2515277 17.00
69-70 AC Idle Solenoid **Harness** 2515278 17.00
W 71 Carb Idle Solenoid **NOS** 3275602 0.00

Idle Solenoid Mounting Brackets **Select from...**

71-74 Q-Jet Mounting **Bracket** 3275601 0.00
71-72 Holley Mounting **Bracket** 3275611 22.00
71-76 Solenoid Mounting Jamb **Nut** 3275603 8.75
72-74 Carb Idle Solenoid **Delco Replmt** 3275614 109.75
72-74 Carb Idle Solenoid **repro** 3275642 79.00
75-76 Carb Idle Solenoid **Delco** 3275622 44.50
75-76 Carb Idle Solenoid **repro** 3275644 29.45
77 & 79-80 Carb Idle Solenoid **repro** 3275646 42.45
78 Carb Idle Solenoid **repro** 3275648 42.45
70-74 TCS Control **Harness** 2515291 19.50
76 L-82 AC Idle Solenoid **Harness** 2515279 17.00

Holley Vacuum Secondaries

These die cast Zinc parts with Yellow Di-Chromate plating regulate the fuel supply when you "Nail it". On 3x2 models, use only on the end carbs; therefore 2 are required.

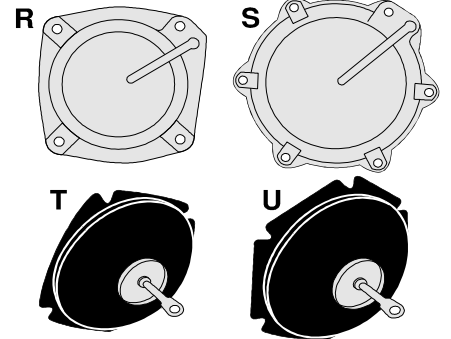

R Diaphragm Cover 1x4 3276412 9.00
S Diaphragm Cover 3x2 3276432 Disc
Cover Mounting Screw Sets
1x4 Cover 4 Piece Screw Set 3276414 5.00
T Vacuum Diaphragm 1x4 3276416 19.50
U Vacuum Diaphragm 3x2 3276436 34.95
Diaphragm Housing 1x4 3276418 13.40
Housing Mounting Screw Set
1x4 Housing 3 Piece Screw Set 3276420 5.45
Connecting Lever & Pin Assembly 1x4 3276422 7.50