

Carburetor Rebuild Kits

Genuine **Delco** or **Holley** kits where noted.
NOT Returnable if Factory Seal **BROKEN**

Carter Carb Rebuild Kits

55-65	WCFB 1x4	3276105	36.50
56-61	WCFB 2x4 2 kits reqd Delco	3276104	38.95
62-65	AFB Delco	3276106	35.30

Holley Carb Rebuild Kits

64-65	350, 365 HP	3276150	47.50
65	425 HP Holley	3276151	47.50
66	300, 350, 390 HP	3276152	29.95
66	425 HP	3276153	47.50
67	300, 350, 390 HP	3276150	47.50
67-69	400, 435 HP 3 kits reqd Delco	3276120	25.00
67-69	430 HP L-88 Holley	3276124	42.50
70-72	LT-1 or 71 425 HP	3276126	54.90

Q-Jet Carb Rebuild Kits

68-69	300, 350, 390 HP Delco	3276132	38.00
70	300, 350 HP Delco disc NOS	3276134	42.50
70	454/390 HP Delco disc NOS	3276136	42.50
70	300, 350, 390 HP repro	3276154	34.75
71-72	350/200 HP Delco \$35.95	3276138	29.50
71-72	454 w/270 or 365 HP Delco NOS	3276140	41.75
71-72	454 w/270 or 365 HP repro	3276154	34.75
73-74	350 or 454 Delco \$44.30	3276142	35.55
75-79	350 Delco \$41.50	3276144	39.50
80	350 Delco \$40.05	3276146	35.00
81	350 Delco \$60.55	3276148	55.00

New Holley Carburetors

Limited New Carbs \$ subject to availability.

64-65	350, 365 HP	#2818	3275122	567.50
66	300, 350 HP Std.	#3367	3275126	549.00
66	390 HP	#3370	3275293	549.00
67	300, 350 HP Std	#3810	3275132	549.00
67	390 HP	#3811	3275146	525.00
67	L-88 427	#3418	3275151	590.00
69	L-88 427	#4296	3275153	650.00
67-69	3x2 End 2 reqd	#3659	3275160	399.00
67	3x2 Center Std	#3660	3275161	525.00
68-69	3x2 Center Std	#4055	3275167	600.00
71	LT-1 Std Trans	#4801	3275184	495.00
72	LT-1 Std Trans	#6239	3275192	495.00

Rebuilt Carburetors

68-82 Q-Jets are quality rebuilt by Holley. Add \$30 core charge. All \$ subject to availability. 90 Day warranty.

58	WCFB	3275326	475.00
59-61	WCFB	3275328	515.00
62	250 HP WCFB	3275330	480.00
62	300 340 HP Std AFB #3269S	3275332	655.00
62	300 HP Auto AFB #3310S	3275334	655.00
63	300 HP Auto AFB #3460	3275336	575.00
63	300. 340 HP Std AFB #3461	3275338	575.00
63-65	250 HP Std WCFB #3721	3275340	460.00
64-65	300 HP Auto AFB #3720	3275342	460.00
64-65	300 HP Std AFB #3721	3275344	460.00
65	425 HP 396	3275124	385.00
68	300, 350 HP 327	3275204	258.00
68	390 HP 427	3275346	239.00
69-70	300, 350 HP Q-Jet 350	3275348	249.00
69	390 HP Q-Jet 427	3275350	258.00
70	390 HP Q-Jet 454	3275352	249.00
71	270 HP Q-Jet 350	3275238	258.00
71-72	454 Q-Jet	3275354	249.00
72	200 HP Q-Jet 350	3275246	269.00
73	350 Q-Jet L-48 & L-82	3275258	258.00
73	275 HP Q-Jet 454	3275268	258.00
74	350 L-48 Q-Jet	3275270	258.00
74	350 L-82 Q-Jet	3275272	258.00
74	270 HP Q-Jet 454	3275274	258.00
75-76	350 Q-Jet	3275276	328.00
77	350 Automatic Trans	3275280	328.00
77	350 Standard Trans	3275284	338.00
78-79	350 Q-Jet Standard Trans	3275286	358.00
78-79	350 Q-Jet Automatic Trans	3275288	318.00
80	350 Q-Jet	3275291	368.00
81	350	3275296	398.00
82	350 Front CrossFire	3275290	389.00
82	350 Rear CrossFire	3275292	389.00

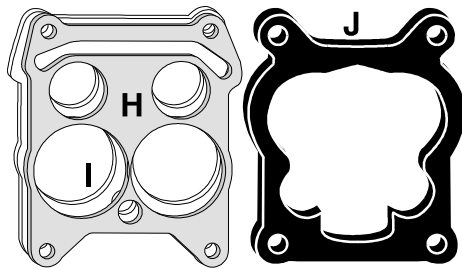

H	68-69 Q-Jet Carb Gasket	3276130	7.00
I	68-69 Q-Jet Stainless Baffle	3275309	11.00
J	70-80 Q-Jet Thick fiber Insulator	3275311	14.00

Carburetor Floats

Floats Are Manufactured From Brass Or A Fuel Resistant Plastic Called Nitrophyll.

K	62-63 AFB 300, 340 HP Brass Float 2 reqd. NOS	3275410	0.00
L	64-65 350, 365 HP Brass Float 2 reqd.	3275412	30.00
M	66-67 300, 350, 390 HP Select from... Above Float in Brass	3275414	20.00
	Above Float in Nitrophyll	3275430	15.00
N	65-66 425 HP 2 reqd; 67-69 3x2 1 reqd use on center carb; 67-69 L-88 2 reqd; 70-72 LT-1 2 reqd; 71 425 HP 2 reqd Brass Float	3275416	30.00
	67-69 3x2 Float in Nitrophyll 2 reqd use on end carbs	3275415	20.00

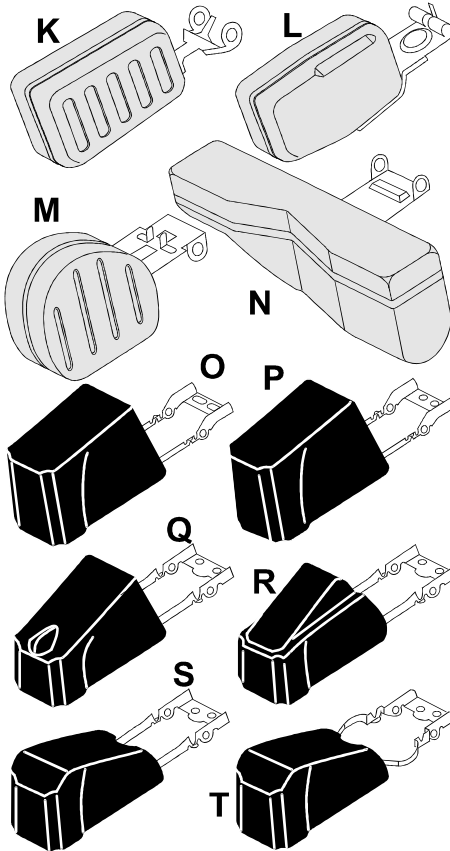

	68 327 or 427 1x4 Brass Float	3275417	20.00
O	68 327 Nitrophyll Float	3275418	20.00
P	68 390 HP Nitrophyll Float	3275420	24.95
Q	69-74 Q-Jet Nitrophyll Float	3275422	22.50
R	75-76 Q-Jet Nitrophyll Float	3275424	24.95
S	77-80 Q-Jet Nitrophyll Float	3275426	24.95
T	81 Q-Jet Nitrophyll Float	3275428	24.95

Carb Air Horn Gaskets

All specific Models Available
Carter WCFB, AFB, Holly, Q-Jet
 All Die Cut to authentic patterns. How come others don't even show you what their "patterns" look like? I guess one round circle in a few sizes fits all. ☺

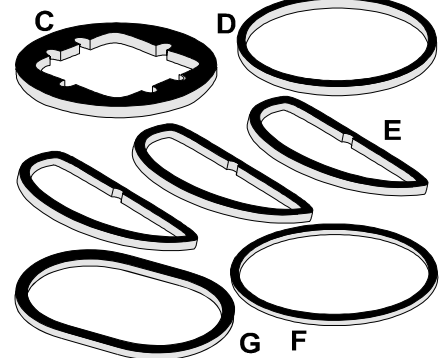

C	55-57 WCFB Air Horn Gasket Contoured Thick Fiber.	3402105	3.50
D	58-65 WCFB or AFB Air Horn Gasket Thick Black Neoprene Rubber.	3402109	3.00
E	67-69 Holley Carb 3x2 Air Horn Gasket 3 Piece Set Does 1 car. Select from 2 different... Cork & Rubber Blend Compositions: Modern 1990's Style Cork & Rubber Blend - that is Durable and Not Brittle	3402189	7.50
	Old 1960's Mostly Cork with Very Little Rubber Blend that is Brittle - Not Durable. This is the material the CRS judges salivate over.	3402193	22.00
F	Holley or Q-Jet Carb Air Horn Gasket Thick Fiber Material.	3402165	3.00
G	82 TBI Carb Air Horn Gaskets Pair Oval Pattern. Does 1 car.	3402190	8.00

Aftermarket Carb Rebuild Kits

58-65	WCFB	3276155	29.25
62-65	AFB	3276156	29.25
Holley 64-65	350, 365, 396; 66 425 70-72 LT-1, LS-6	3276157	38.00
Holley 66	300, 350, 390	3276158	30.00
Holley 67-69	3x2 400, 435	3276159	29.25
Q-Jet 68	327 or 427 1x4	3276160	30.00
Holley 67-69	L-88	3276161	38.00
Q-Jet 69-71	350; 72 454	3276162	25.00
Q-Jet 72	350	3276163	25.00
Q-Jet 73-74	350 or 454	3276164	25.00
Q-Jet 75-78	350; 79-82 L-82	3276165	29.25
Q-Jet 79-80	L-48	3276166	27.75
Q-Jet 80	Calif; 81 All	3276167	32.50

Intake Engine Lift Brackets

Engine Lift Brackets bolted to the intake were used for lifting at the assembly plant & were delivered on each Corvette.

68-69	3x2 Engine Lift Brackets Pair	3027135	11.00
68-70	327 or 350 Engine Lift Brackets Pair	3027136	22.00
68-74	Big Block exc 3x2 Lift Brackets Pair	3027137	22.00
71-82	350 Engine Lift Brackets Pair	3027138	22.00